

SUPPORTIVE SKILLS AND TECHNIQUES

FITTING A BRIDGE TO A PROFESSIONAL QUALITY INSTRUMENT

By Lars Kirmser

FITTING THE BRIDGE

TOOL AND MATERIAL REQUIREMENTS:

- **Belt Sander**
- **Stanley 9 1/2 Block Plane**
- **Violin Knives (5mm, 10mm, 15mm)**
- **String Height Projection Sticks (complete set)**
- **Bridge Templates (complete set)**
- **Slotting Files (or equivalent)**
- **Rat Tail File**
- **Mill Bastard File (med.)**
- **Bridge Holding Jigs (set)**
- **Sanding Papers**
- **Linseed Oil (opt.)**
- **Ammonia (opt.)**
- **Parchment Paper**
- **Alaphatic Resin (Carpenter's) Glue**

Bridges on instruments of the Violin Family are made of a unique grade of maple. This select maple is precisely cut on the quarter, and as the result, reveals a distinctive pattern known as "flake". Bridges on the violin family are freestanding, never being affixed or glued to the instrument's top, but rather being held in place by the tension of the strings passing over them.

The bridge, of course, is the first and one of the more important links in the transmission of vibrations directly from the strings to the hollow enclosure of the instrument. The precision with which the bridge is cut and fitted to the specific instrument will largely determine the character and quality of that instrument's voice. Much of the process will be very specific where a number of important criteria must be carefully attended to, however, there will be elements within the process that are considered to be arbitrary, and offers the luthier an opportunity to assign his own "signature" to each bridge he installs. As a repair technician, the installation of a bridge is one of the rare occasions where you will be allowed to project your own signature to your work, as

long as it is consistent with good taste, and only after all technical criteria are successfully met.

SELECTING THE BRIDGE

The first step is to select a bridge blank which will be appropriate for a given instrument. In making this decision you will want to consider both the specific dimensional requirements of the blank as well as the unique physical qualities of the wood from which the blank was made (relative hardness, figure, "cut", etc.). 4/4 Violin bridge blanks are fairly standard at approximately 41mm from the outside of one foot to the outside of the other, so there is little choice to be made here. Viola bridges, on the other hand, will have a range of from 46mm up to 50mm. The smaller size bridge blank would be appropriate for a (small) 16" (407mm) viola, while the larger size blank would be used for the larger model violas (i.e. Tertis model). In the final analysis, the actual process of selecting the bridge blank will be determined by the specific dimensions and model of the instrument.

SELECTING A BRIDGE BLANK FOR 'CELLOS AND DOUBLE BASSES

Before you begin fitting any bridge, make sure that the soundpost is set in its correct position as this will change the overall height and shape of the top plate ever so slightly. Once you are sure the soundpost is correctly placed and in good adjustment, you will begin by measuring the distance to the bass bar from the edge of the left f-hole. Mark this distance off on the top of the instrument with a china marker (don't damage the finish!). Perform this same procedure on the soundpost side (both measurements should be identical). After these two measurements have been marked on the top, measure the distance between these two points and add 5 to 6mm for 'cellos and 8 to 10mm for double basses. The distance between these two marks then represents the outside measurement at the base of the bridge blank that you will work with. On occasion, this number may be absurdly out of the range of normal bridge sizes. For example, a standard 'cello bridge size is 90mm, but you can purchase them ranging from 87mm all the way up to 94mm. If an instrument is unorthodox in its standard measurements, simply use the closest sized blank that you have in stock. Do not attempt to make one from scratch.

Usually, only manufacturers of better quality bridge blanks will offer you an adequate range of bridge sizes. And, since only instruments of sufficient quality will require this consideration, you need not be overly concerned with having to maintain an extensive inventory of bridges, unless of course you want to specialize in the repair of artist quality instruments. On most occasions a standard bridge will be quite adequate, so on student and intermediate quality instruments where a less expensive blank is called for, this consideration will be, for the most part, academic. To be sure, it is usually possible to trim out a standard size bridge in such a manner as will effectively suit the requirements of a particular instrument.

When you have determined the size bridge blank you require, you must then select a blank with the appropriate *physical* qualities. Two considerations must be made here, the first being the *type* of wood, the second being the *cut* of the blank. Wood, being the natural material that it is, will exhibit a wide range of physical charac-

teristics. For example, it can vary from being tremendously hard to quite soft, flexible to stiff, highly figured to plain. Its largely a matter of experience for one to be a good judge of wood types. As a consequence, it will probably be rather confusing to you at first, but my suggestion would be for you to begin by carefully examining and testing the bridges which you have in your inventory as well as those that routinely come across your work bench. Begin by flexing them between your fingers and thumbs to get a sense of their relative strength. Drop them on a hard bench and listen to the relative *ping* they make as they rebound off the hard surface. Those with a defined ringing will be harder (more dense) than those that exhibit more of a *thump*. Take note of how they feel under your plane and knife as you work with them. Later, when we begin our acoustical studies we will attempt to make a systematic analysis of many of the variables, but for now simply try to gain a general *feel* for their relative physical qualities.

Finally, in selecting a bridge (and also when purchasing your inventory) you should be aware of the *cut* of the blank itself. Remember, you can't put wood where no wood exists, so if your blank is too thin or too narrow in an area which we consider to be important, then you will simply be wasting time and money by trying to work with it. As you gain experience and begin to have an idea of the general type of blank you like to have in stock, you can check with various suppliers to locate what you need, or if you want you can even work with a manufacturer to produce the style you desire. Naturally, you will be expected to pay a premium price for such a service.

PREPARATION OF THE BRIDGE BLANK

First, begin by taking your violin knife and carefully trim off the corners of the protruding ornamental features in the so-called *ears* and *heart* of the bridge (see illustration). This will prevent the accidental breaking off of these parts by being caught by the plane or sander later.

Next, you must determine which side will be the front of the bridge. The front is the side that will face the fingerboard; the back is the side which will face the tailpiece. The best way to establish this is to look at the edge of the bridge to see which way the white wood rays lean.

The rays will be nearly vertical, but they will usually run out toward one face more than the other. Make the side they run out to be the back of the bridge. When you assign this side as the back, there will be a tendency for the wood to have more resistance to warping forward, which can be a very common problem, especially on the 'cello and double bass. As it turns out, the surface pattern of the back side will appear as a figure of smaller, more defined round *flecks*, while the front side will have more elongated ones. Incidentally, the back-side of the bridge *should* be the side with the trademark, so this whole decision becomes mute if the manufacturer has already made this decision for you. On the other hand, you can sand off the trademark and reassign the back side if you desire, as long as the trademark is unimportant to the client.

is made "by the numbers" so to speak and will allow us to get some preliminary indications of how our blank will relate to the unique dimensions of the instrument at hand. You will prepare this template according to the standard measurements of the model being worked on. The template usually consists of a full blank with flexible feet (i.e. de Jacques type) that will easily conform to the contour of the top, and have a dark line drawn across its face to indicate the finished profile as determined by the fingerboard to bridge string projections. Eventually, you will want to have a sample template for each nominal size of all the instruments in the violin family. The sample bridge template will allow you to predict with relative accuracy the compensations that must be made when cutting the bridge blank so that you can adjust for any irregularities unique to the instrument we are working on.

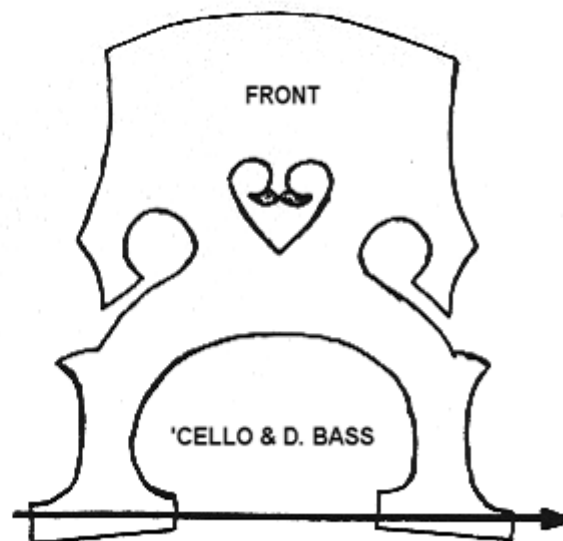
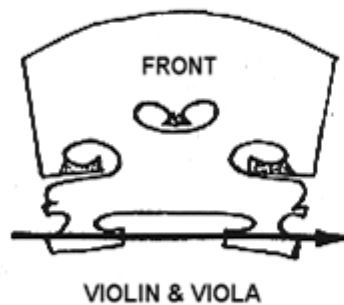

The next step will be to plane the feet of the bridge on the *front side* of the blank to a thickness just a bit thicker than your anticipated finished thickness. The finished thickness for violin is 4.4mm, viola 4.7mm, 'cello 11.6mm, and double bass 21mm. Plane generally across the feet as indicated by the arrows in the illustration above and check the thickness of the feet from time to time with your dial caliper. Plane as parallel to the opposite surface as you can, thus limiting your planing to the feet portion only, and not the entire front face.

If the instrument is not already marked out for a *sample bridge template*, do so now. A sample bridge template

Hold the sample bridge template in place and sight down the fingerboard. You will first note the relative height of the fingerboard with respect to your dark line, secondly, you will note how well it is centered with respect to your sample bridge. Carefully noting these two factors will allow you to accurately determine exactly how you will need to cut the feet and/or crown of your bridge blank.

Ideally, you will want the heart of the finished bridge to be approximately in the center of the main body of the bridge. So, if the fingerboard is high with respect to the sample bridge, it will be necessary to leave a corre-

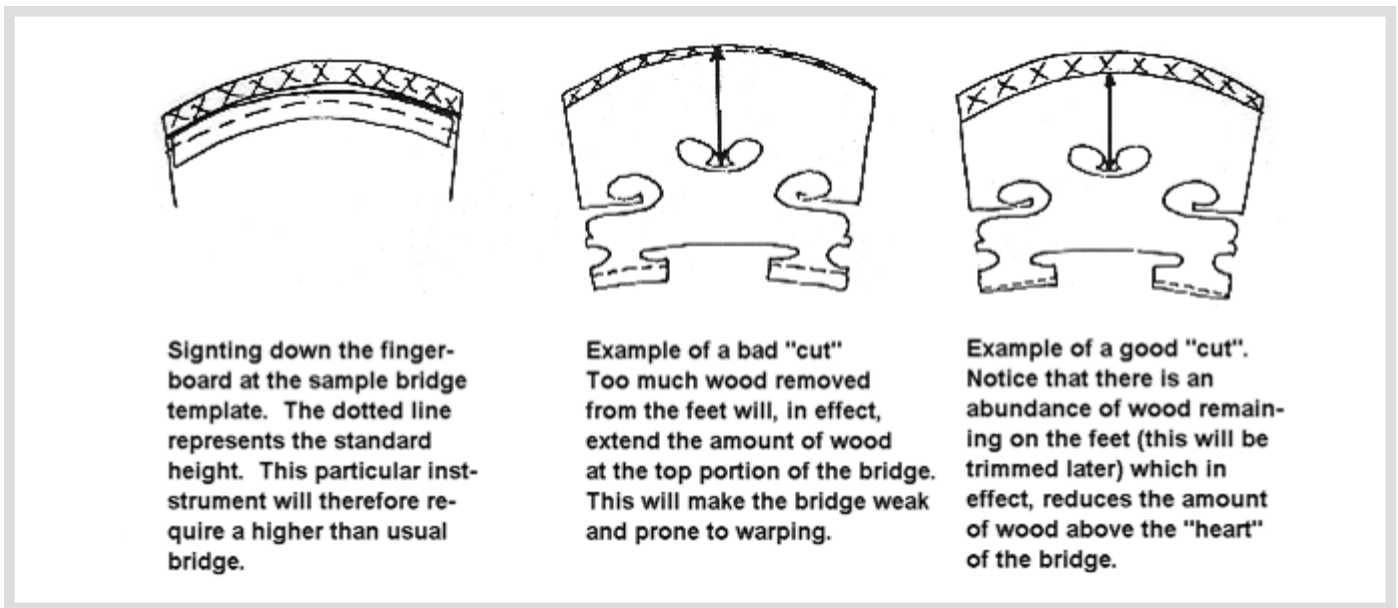

sponding amount of *meat* on the feet of the blank (to raise the body of the bridge higher). On the other hand, if the fingerboard appears low with respect to the line

on the sample bridge, you will want to take off a corresponding amount of wood from the blank's feet, thus bringing the body of the blank into an acceptable range with respect to the fingerboard.

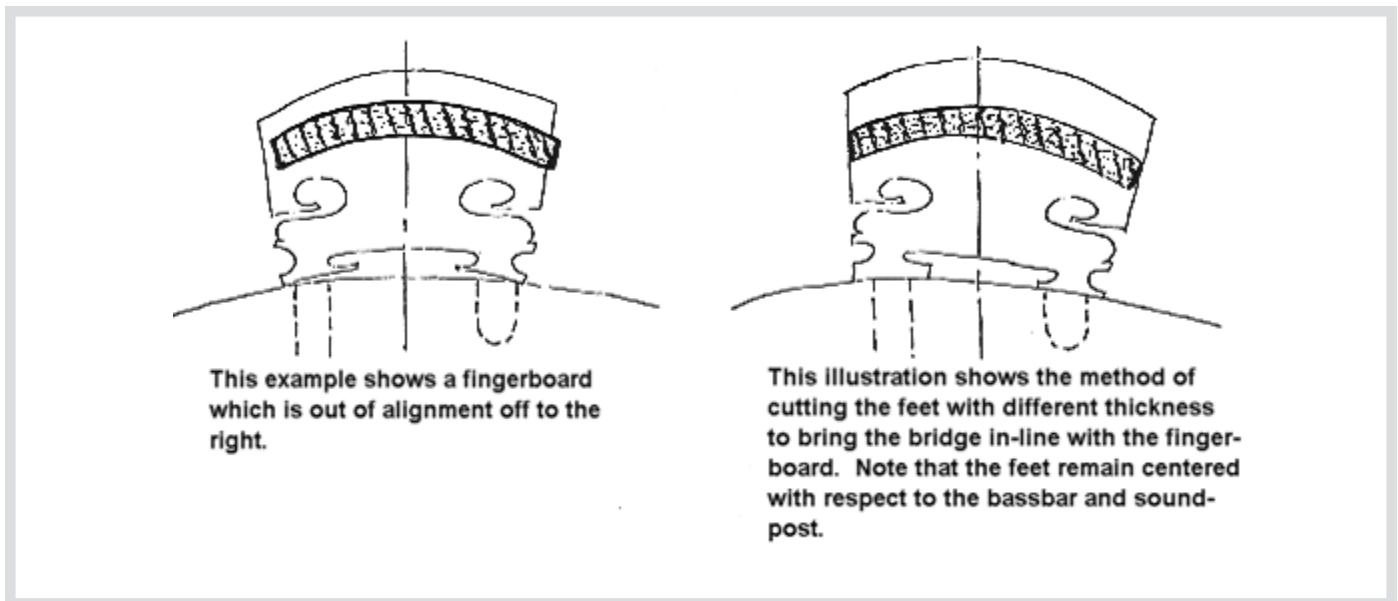

Similarly, if the angle of the neck is off to one side, you will want to bring the body of the bridge into alignment with it as much as is possible by removing more wood off the foot on the side toward which your need to move. The reason here is that the principle of symmetry is very important to the balanced good sound of an instrument.

We already know that the bass bar and soundpost are balanced evenly on each side of the center of the instrument, so naturally, we will want to keep the bridge centered as well. In this manner we are able to adjust the crown of the bridge relative to fingerboard and at the same time keep the feet evenly and equally spaced on the top of the instrument.

FITTING THE VIOLIN AND VIOLA BRIDGE

We shall begin by making the initial *trim* on the feet of the bridge blank. If a substantial amount of wood must be removed from the blank, then it may be advisable for you to use the belt sander. Before sanding the feet, make sure that the belt sander table is exactly perpendicular to the face of the belt. It is important to have the back side (trademark) of the blank facing down when sanding the base of the feet since the back side of the finished bridge should be at an exact 90 degree angle with respect to the belly of the violin. Prior to sanding, make a light pencil line on each foot allowing for 2 or 3mm more wood than you expect your finished thickness will be. If only a small amount of wood is required to be removed then you may want to remove it with your violin knife (12 - 15mm), as the knife offers more precision than the belt sander. When using a knife, I

prefer to use one with a slightly wider angle at the tip, but this is my own preference and you may prefer a more pointed blade. Hold the bridge blank such that the bottom of the feet are facing up-

wards, and begin by making a *paring* cut from outside of the first foot towards the inside. Hold the blank such that you are able to comfortably (and safely!) make the cut towards yourself. Be sure to offset your thumb slightly with reference to you knife blade (when your making a paring cut) so that you wont cut into your thumb if the knife slips. Remember, ANYTHING that is in front of any sharp blade (knives - chisels - gouges) is fair game as far as the blade is concerned - blades have an IQ of approximately 0 and are unable to discriminate! So, think twice before cutting. OK, continuing on Throughout this whole process we must always keep in mind that our goal is first of all, to trim the feet such that they fit against the top plate precisely where all 4 edges of each foot set firmly and evenly (no gaps!), secondly, we want to end up with the feet at precise thicknesses, and thirdly, we must maintain the 90 degree angle at which the bridge will sit with respect to the tailpiece side of the instrument's top. The importance of this 90 degree angle cannot be underestimated as it will allow for approximately equal angles on each side

of the bridge with respect to the strings passing over. And, as a consequence will provide an evenly balanced downward pressure on the instrument's belly, thus avoiding the propensity of warping later on. When correctly placed, the bridge will appear to be leaning slightly backwards toward the tailpiece when sighting from the side, and a perfect right angle will be present with respect to the top on the tailpiece side of the bridge (see illustration>. As we proceed later on, the thinning-out of the bridge will come from its front side, that is, the side with the elongated-shaped flake (lacking the trademark). When the bridge angle is, in fact, correct there will be appear to be a slight backward leaning effect, while the back side of the bridge should remain absolutely perpendicular to the top plate. When trimming the feet, an attempt should be made to maintain these relationships.

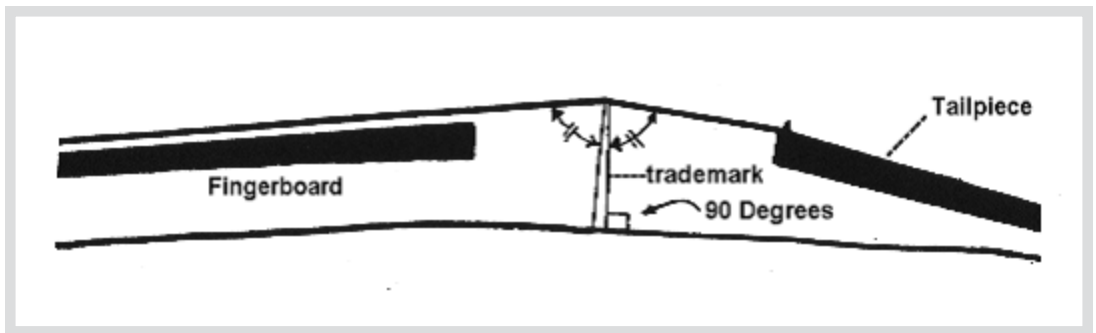

As you are making your cuts, it is advisable to position the bridge on the instrument from time to time to monitor and evaluate your progress. This, of course, requires a critical examination of both the front and backside of the bridge noting where gaps exist or adjustments must be made. For example, if the E foot of a violin bridge looks like this:

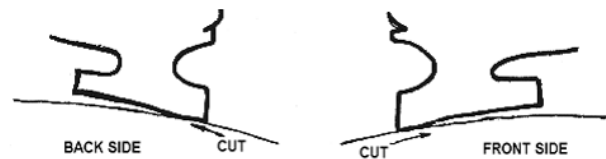

This indicates that material needs to be removed from the *outside* of the foot; both front and back, but more on the front side. Your next cut should remove material like this:

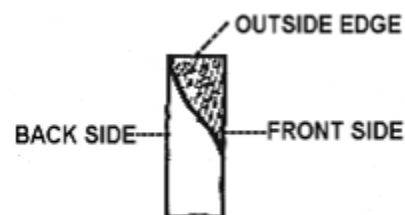

In the beginning, aim towards getting both feet to fit roughly, then start making more precise *finish* cuts. A slight lick of the tongue to moisten the bottom of the foot will allow you to remove paper-thin slices of wood. Since the grain runs straight across the bridge, and the feet will angle upwards and inwards for the arching, you are unable to cut from inside to outside, since this would be going against the grain and may very well cause you to tear out small chunks:



However, at the very outside of the bridge feet, where it is difficult to make fine cuts towards the center, you can cut *against* the grain by taking a VERY thin cut with a lot of slicing movement. DO NOT wet the wood for this kind of cut as this would only further the tendency to split along the grain. Needless to say, you will have to maintain the edge of your knife.

Continue cutting until both feet exhibit a perfectly flush fit. Make sure that your alignment of the bridge crown is not “wandering” as you make slight adjustments on the feet. This is often easier said than done, since it is entirely impossible to fit each foot individually without affecting the other, and consequently the final alignment with respect to the fingerboard/neck alignment. When complete, there should be an absence of “rocking” on the free standing bridge, and, with a very light downward pressure you should be able to cause each foot to become perfectly flush with respect to the top; a fairly large order for the neophyte, however, the more bridges you work with, the easier this whole process becomes.

FITTING THE ‘CELLO AND DOUBLE BASS BRIDGE

Once you have determined which side of your ‘Cello or Bass bridge blank will be the front and that which will assigned as the back, you will begin by spreading the feet of the new blank slightly by inserting a precisely measured piece of wood dowel between the legs. A 4/4 ‘cello will require an approximate 1.5 - 2mm flex, and a 3/4 (standard) double bass will require approximately 3 to 4mm. This, of course, is necessary because with the

longer, more flexible legs of these larger bridges we experience a certain amount of outward flexing of the bridge feet when the strings are brought up to pitch causing the feet to spread out a bit. If you fail to include this step, you will not be able to achieve a precision fit. This spread will usually be relatively slight and will be determined for the most part by the relative curvature of the bridge arching (the higher the arch, the more spread).

Having done this, take the old bridge (if one exists) and place it on top of the front side of the new blank in such a way that you can scribe the feet curvatures on it, allowing for the desired foot thickness. If an old bridge is not available, you may place the new bridge in position and draw a pencil line along the bottom of each foot using the adjacent curvature of the top to guide your pencil. Or better yet, if you have a Roth de Jacques (self-adjusting swivel feet) handy, you may use it as a template for transferring these cut lines. It would be my recommendation to acquire a de Jacques bridge for every nominal size available (all violin family) to be used in this manner.

Once these reference lines have been established, you may use a bandsaw to remove the excess wood allowing a little extra material to remain for adjustment purposes. Again, be sure to place the bridge with its backside down to establish the 90 angle that must exist with respect to the instrument’s belly.

You may now proceed as described earlier with respect to the violin and viola bridge. After getting the feet to fit closely, and having removed all the saw marks, you may now isolate any “high spots” present on the bottom of the feet by drawing a small rectangular piece of carbon paper beneath each foot (carbon side up of course). This will allow you to easily see those spots on the feet which must be carefully pared down with your violin knife to form a precision fit. Continue this technique until the carbon marks pretty much cover the entire base of each foot. You may then further precision adjust the fit with a scraper. Complete this step by removing all traces of carbon paper and carefully check the fit. A feeler gauge, similar to that which is used in woodwind repair may be used to indicate the precision of your fit.

PROJECT THE BRIDGE HEIGHT AND ESTABLISH THE CURVATURE

It is at this point that you will position your newly fitted bridge into position with your bridge-holding tool (see illustration). Next, you will select the appropriate projection stick for the instrument being worked on, and project a treble string reference line and a second bass string reference line directly on the front face of the bridge. Make sure that the reference line is exactly at the point where the string will end up resting. Small errors at this point will be significant later on, so be careful. You may now select the appropriate bridge curvature template and line up the treble side of the template with the projection mark of the treble string. Line the other side of the template with the projection mark of the bass string. Make sure you don't have your template wrong side up! Next, with a very sharp pencil (or razor blade) scribe a light line across the top of the template. This line will indicate the plane upon which the strings will finally reside. Next, you will carefully remove the excess wood with the bandsaw or jigsaw leaving at least 2mm excess for good measure. If only a small amount of wood is to be removed from the blank, you may carefully pare this excess off with your violin knife or you may choose to sand it off (carefully!) with the belt sander. In any case, you should allow for the eventual string slots.

maple to establish the adjustment. Be careful that you do not make the center (just below the heart) of the bridge too thin as this will likely lead to poor tone quality and be prone to warping. Since the bridge is tapered, and the sides of the crown (arch) are lower than the middle, it will be necessary for you to plane more material from the outside edges where it is thicker. A good method is to plane radially from the center of the bridge outwards.

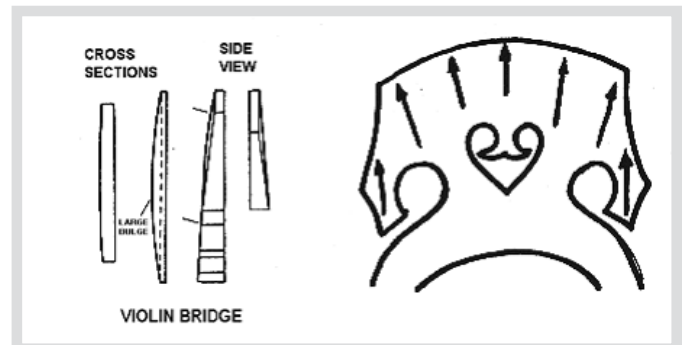

TRIMMING THE BRIDGE

It is now time to trim away any excess wood mass from the bridge so that we may satisfy the acoustic requirements first, and secondly install the aesthetic qualities as well. Remembering that a mass such as the bridge will either translate the vibrations of the strings effectively, or, if too massive may reject or subdue the vibrations.

Our task will be to determine a precise balance between weight (mass) and necessary strength. And, in doing so, the primary object will be to reach a delicate balance among three qualities: freeness of vibration, overall strength, and durability.

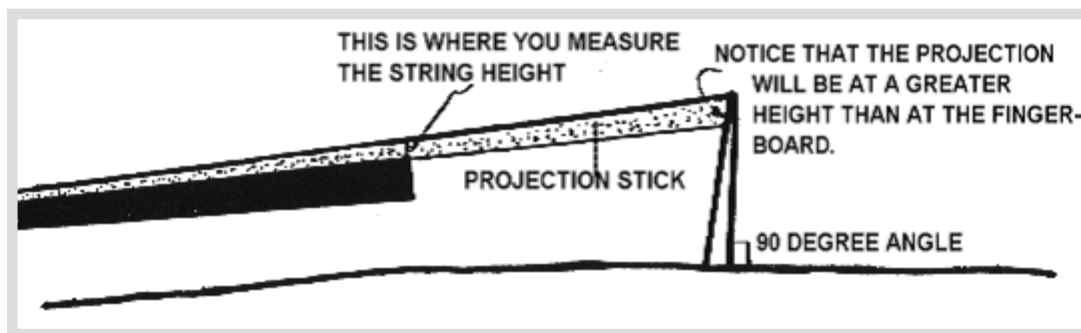

PLANING THE BRIDGE TO THICKNESS

You may now begin to plane the front side of the bridge with your Stanley 9 1/2 block plane. This may be effectively done by placing the blank securely into a holding devise and planing the blank down to the recommended thickness (see specs).

Be sure to plane from the bottom to the top as shown below, and set the plane for a very fine cut and a very small throat opening. Test your plane on some scrap

I would suggest that you use a slightly narrower knife for the violins and violas, and a larger bladed knife for the 'cellos and basses. Be sure to adhere to the recommended dimensions as closely as possible, and if necessary, you may want to exceed the dimensions if the wood is inherently weak or if you just want to leave more mass for acoustic reasons I recommended that you preform this step in the following order: Begin by trimming the *ears*, then proceed to the inside of the feet,

next the outside of the feet, followed by the bottom arch, any special alterations necessary in the upper body, then finally, all the small aesthetic touches that add to the overall finished look. The particular shaping and specific methods of cutting used for each type of bridge will vary from one technician to another, but there are several key points to remember.

FOR VIOLIN AND VIOLA:

- The ears are trimmed from basic rectangular lobes to a more pointed shape:
- The feet on the inside are trimmed mostly on the top of the foot (which should not slope too much)
- Measure the internal distance from leg to leg to make sure that you get as close as you can to the standard measurement there. Do not make the bottom arch too rounded. The outside of the feet are trimmed with a curve as follows:

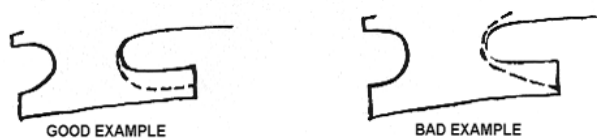

FOR 'CELLOS AND BASSES:

Start with the slope of the upper leg, where it comes out of the curve of the ear and proceeds down to the bumps. Within the bounds of the minimum dimensions, take away any hump and make a smooth flowing transition from the ear to the lower leg. Now make the ear itself into a round pointed oval (if it is not already) as shown below:

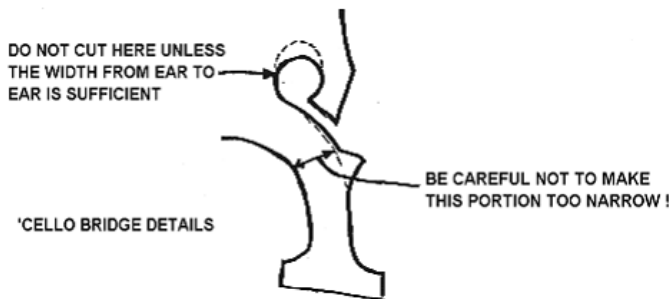

Next, trim out the feet and lower legs. The inner foot curve should be sharper than the outer one. Start to smooth the inner leg surfaces into a nice bottom as in the following manner:

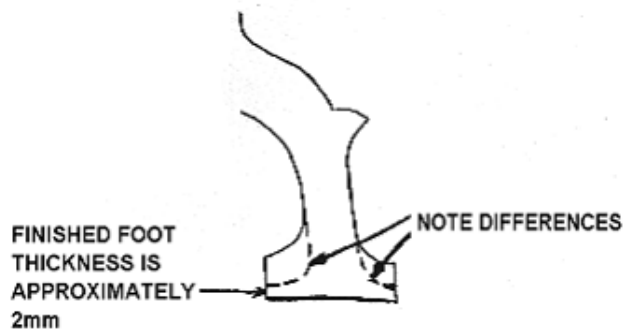

It is in trimming the foot and leg that you are able to do a little shifting in the total bridge width. If you want a narrower bridge, do most of the leg trimming from the outside. It will then be necessary to trim a little from the outside of the feet. Cut the length of each foot down from the inside to a MINIMUM of: violin - 11.5mm, viola - 12.5mm, 'cello - 23.5mm, and double bass - 43mm.

FINAL FINISHING

Complete all of the fine details remaining at this point, then check the bridge as a whole, focusing on the lines of your curves. The bridge derives a finished look from all the subtle decorative touches, but derives a much more fundamental elegance from the smoothness and balance of your curves as well as from a general per-

ception of style which is consistently executed throughout the bridge. In your first attempts, work on acquiring the general knife skills so you are able to cut where you want, in the manner you want. As you acquire skills in the functional aspects of bridge making, you may then begin to concentrate on the elements of its form, that is, to work on developing its beauty within the limits of strength and good acoustical properties. . . .one that is uniquely your own.

When the trimming-out is essentially complete, use your sample bridge template or calipers to mark out the string notches, spacing them evenly on the bridge. Install the strings and bring them up to a moderate degree of tension. Verify each string's clearance at the end of the fingerboard, and if any adjustments must be made, insert a bridge jack beneath the strings so that you can remove the bridge and make the required adjustments. Replace the bridge, check again, and continue this process until the strings are at their correct heights with respect to the fingerboard. As a final step, place the bridge jack in position and remove the bridge for the last time so you may put the final finishing touches on it. Begin by sanding the surface with fine #320 sandpaper until all marks and blemishes are gone. If the bridge is without an ebony insert, you must provide parchment reinforcement over the treble string slots to help keep them from wearing the string slot prematurely. To prepare the parchment begin by soaking some small pieces in plain water for a few minutes. Parchment will be placed over the slots for the E string on the violin, A string on the viola, and the A and D strings on the 'cello. The small rectangular pieces of parchment will be glued into position with a small dab of Titebond (alaphatic resin) adhesive. Allow the freshly glued parchment to dry in place while you give the bridge a light coating of linseed or lemon oil. Some luthiers will hang the bridge in a jar of ammonia to artificially age the wood. If you use this method, do not allow the bridge to submerge in the ammonia. Instead, pour a small quantity of ammonia in the bottom of a jar and suspend the bridge from a wire running through the lid. Be very careful of the ammonia fumes as they can be quite dangerous if inhaled! Work in an area with good ventilation. The bridge should now be complete and ready to be placed on the instrument.

4/4 VIOLIN BRIDGE

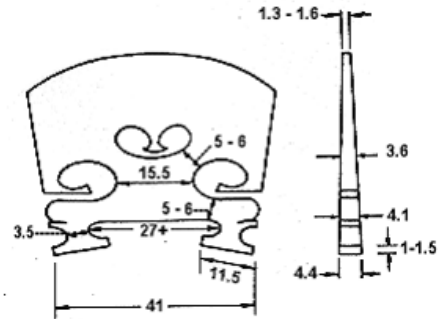

All measurements in millimeters

Medium Viola Bridge

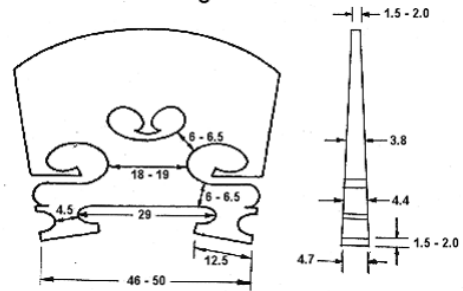

All measurements in millimeters

4/4 'CELLO BRIDGE

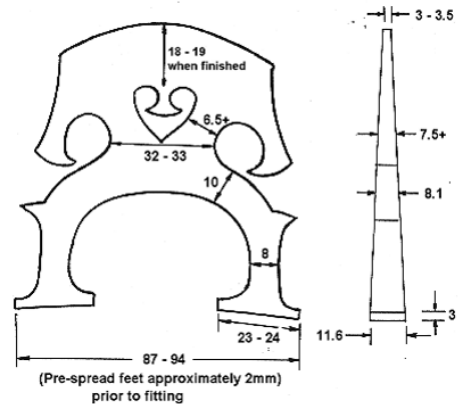

DOUBLE BASS BRIDGE

